

Temperature Controller-2 Set Point

Specification

- 1). Display : 4 Digit (0.56") for PV
- 2). Range : RTD Type -99.9 to 399.9 deg
: J Type : 0 to 600 deg
: K Type : 0-1300 deg
- 3).Resolution : 1 deg (J/k) and 0.1 deg (RTD)
- 4). Accuracy : $\pm 0.5\%$ (Full Scale)
- 5). Hysterisis : 0 to 99°C
- 6). Offset : -100 to 155°C
- 7). Alarm Action : Heat/Cool Selectable
- 8). Control Action: ON-OFF / TP Action

Set Points

- 1) Set Point one can be viewed by pressing **SET** key once
- 2) Set Point can be changed by pressing **SET** key+ **↓** & **↑** keys.
- 3) Set Point Two can be viewed by pressing **SET** key twice
- 4) Set Point two can be changed by pressing **SET** key+ **↓** & **↑** keys.

Procedure to Program

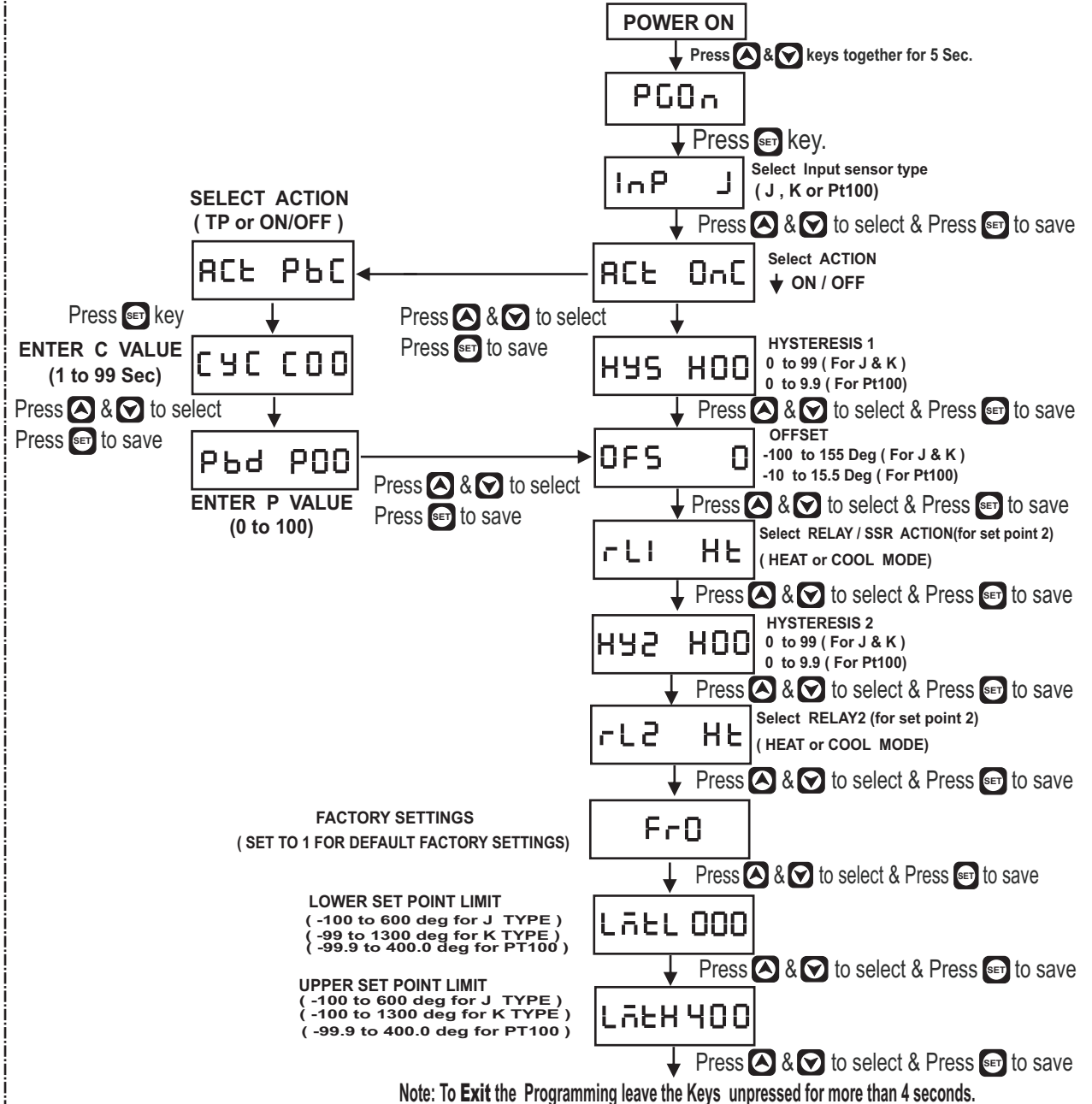

Note: To Exit the Programming leave the Keys unpressed for more than 4 seconds.